



Terry 
total mobility solutions

TSL 1000 DOMESTIC STEPLIFT

TSL 1000 Domestic Steplift

Practical: provides both wheelchair and pedestrian access at the same doorway - inside or outside

Easy to use: convenient controls (remote option available) and shallow approach ramp

Easy installation: Self contained unit is suitable for mounting on a flat 100mm concrete base and can be installed in less than a day

Cost effective: often cheaper than a ramp and can be easily re-sited

Reliable: battery back-up provides normal operation (up to 30 cycles) in case of power cut

Low maintenance: annual servicing recommended. Maintenance contract available

Safe: built in the UK to BS 6440 by a Company with over 30 years' experience in mobility and access products

Versatile: the lift will travel up to 1000mm with upper gate protection or 960mm with a triple bridge unit

Unobtrusive: blends into its surroundings

Standard Specification

Application range: Can be sited internally or externally for wheelchair users only

Maximum safe working load: 250Kg

Closed height: 75mm

Maximum height served: 1000mm

Power supply electrical requirements: 220 / 240V~50 / 60 Hz-13A single phase

Low voltage control system: 24V DC

Operating temperature range: -10°C to +40°C

Safety: Automatic wheelchair arrestor mechanism and full battery back-up. Constant pressure controls

Drive: Bellows enclosed hydraulic scissor mechanism

TSL 1000 Lift Dimensions (in mm)

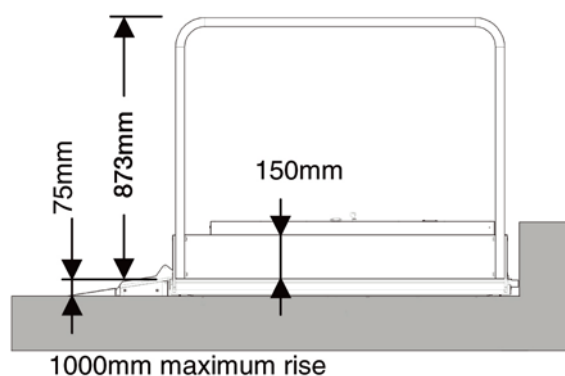
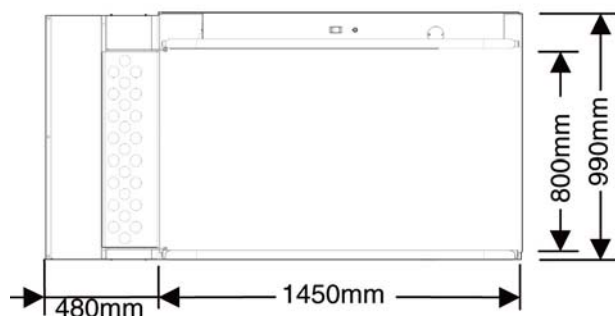

Terry 
 total mobility solutions

Terry Group Ltd.
 Longridge Trading Estate, Knutsford,
 Cheshire, WA16 8PR, England

Tel: 00 44 (0) 1565 650376
 Fax: 00 44 (0) 1565 755062
 web: www.terrylifts.co.uk
 email: sales@terrylifts.co.uk

